

User's Manual  
PLC09 Modbus Converter  
for  
PAL-AT Leak Detection System

PermAlert ESP  
7720 Lehigh Ave.  
Niles, IL 60714  
847-966-2190



## INDEX

1.0 Introduction	4
1.1 Features	4
2.0 Installation	4
2.1 General	4
2.2 Port Connector Pin Assignment	4
2.2.1 Port 1 (Modbus Host)	4
2.2.2 Port 2 (Configuration)	4
2.2.3 Port 3 (PAL-AT)	4
2.2.4 Port 4 (Spare)	5
2.2.5 Power	5
3.0 Mode of Operation	6
4.0 Configuration Dialog	7
4.1 MODBUS/PAL-AT ADDRESS	7
4.2 HOST MODBUS PORT RATE	7
4.3 MODBUS FORMAT	7
4.4 PAL-AT PORT RATE	7
4.5 PAL-AT POLL DELAY TIME	7
4.6 MODBUS RTS CONTROL – OFF (0), ON (1)	8
4.7 MODBUS RTS TX DELAY T.O.	8
5.0 Radio Frequency Information	8

## 1.0 Introduction

The PLC09 is equipped with four serial RS-232 asynchronous ports. For this application the software has been designed to connect to a Host computer using Modbus RTU Protocol on one serial port (labelled Port 1) and PAL-AT on another port (labelled Port 3). Port 2 is used for configuring the PLC09. The unit is equipped with battery backed up RAM which holds the configurable parameters.

### 1.1 Features

Power Up Check	On power up, the unit checks EPROM memory, RAM memory, configuration parameters, and its database for validity. If a fault occurs, the LED on the front of the unit will blink once every 1.5 seconds for an EPROM problem, twice every 2.0 seconds for a RAM problem, and three times every 2.5 seconds if the default configuration has been restored. Powering the PLC09 off and on can reset the flashing, if it is due to a one-time event. If there are no errors, the LED is used as an activity timer by the software executive. The brighter the LED the less busy the unit.
Modem RTS	Ports 1 can control RTS for a 202-type modem or radio in order to turn carrier on and off.

## 2.0 Installation

### 2.1 General

The rear of the PLC09 Unit contains five connectors, and a pushbutton switch (see figure 1). The first connector on the right is Port 1 (Modbus RTU), followed by Port 2 (configuration), Port 3 (PAL-AT unit) and Port 4 (spare). Next is a pushbutton used for initiating the configuration mode followed by the mini power jack for the plug-in power supply.

### 2.2 Port Connector Pin Assignment

#### 2.2.1 Port 1 (Modbus Host) (9 pin female DB9 connector)

- Pin 2 RX data (input)
- Pin 3 TX data (output)
- Pin 4 DTR (output) Held high through 3 K. res. to 5 V.
- Pin 5 Ground
- Pin 7 RTS (output)

#### 2.2.2 Port 2 (Configuration) (9 pin female DB9 connector)

- Pin 2 RX data (input)
- Pin 3 TX data (output)
- Pin 4 DTR (output) Held high through 3 K. res. to 5 V.
- Pin 5 Ground

#### 2.2.3 Port 3 (PAL-AT) (9 pin male DB9 connector)

- Pin 2 RX data (input)
- Pin 3 TX data (output)
- Pin 4 DTR (output) Held high through 3 K. res. to 5 V.
- Pin 5 Ground
- Pin 7 RTS (output)

2.24 Port 4 (Spare) (6 pin Telco RJ-12)

- Pin 1 Ground
- Pin 2 DTR (output)
- Pin 3 RX data (input)
- Pin 4 TX data (output)

2.25 Power (female power mini jack)

- Tip 9 to 12 VDC
- Ring Ground

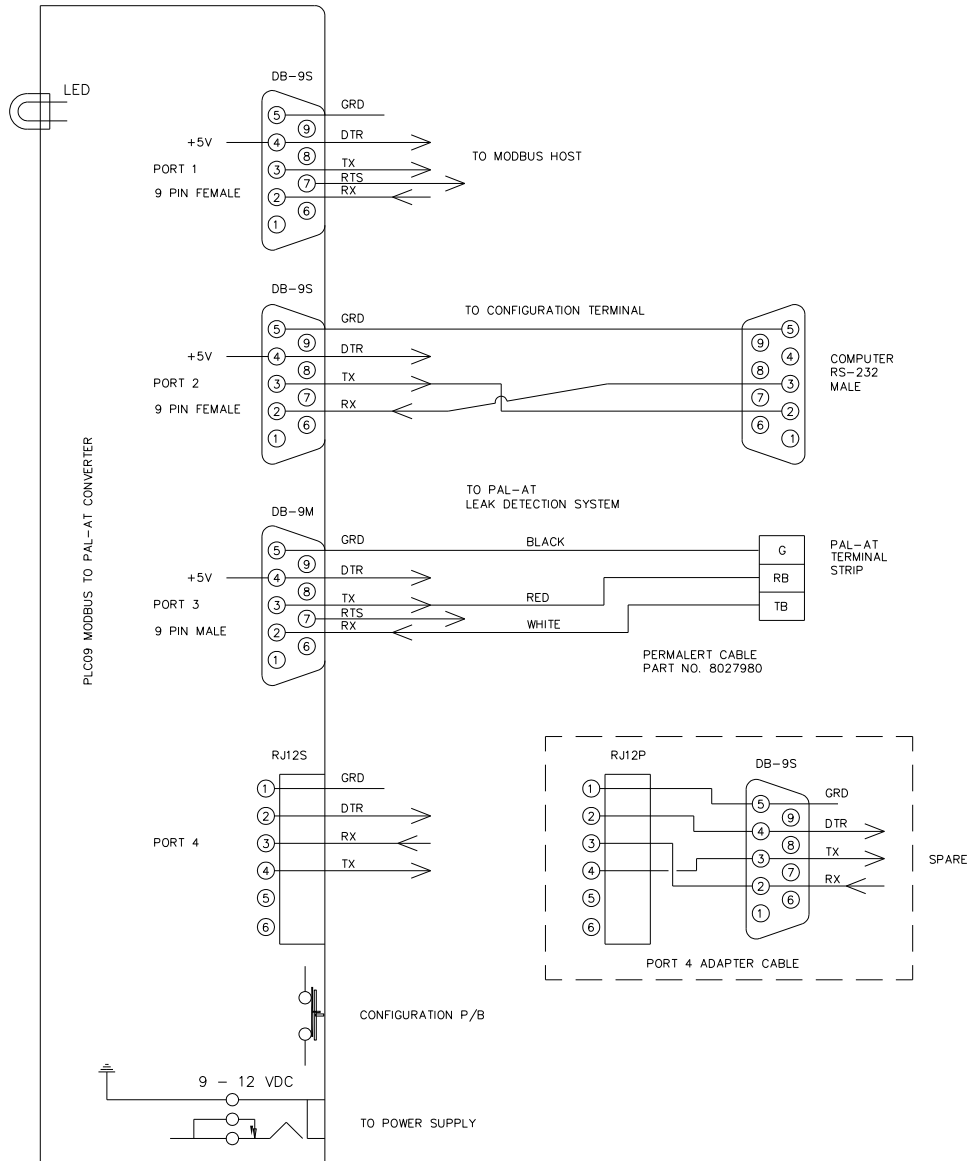

Figure 1 PAL-AT To PLC09 Connection Diagram

### 3.0 Mode of Operation

The PLC09 Interface Unit Host 1 port is configured as a Modbus Slave. It is set up for communication with a Host using Modbus RTU protocol. The baud rate and asynchronous format are configurable.

The unit will respond to poll requests (Modbus function code 3) for the configured Modbus Slave address. Only holding registers 1 to 17 are valid.

Function code 3 is used to retrieve the cable status values sent to the PLC09 unit from the PAL-AT Leak Detection Unit. All values are integer. All data will be referenced to the start holding register address of 40001 in the following manner.

40001	Pal-At communications status (0=okay, 1=trouble)
40002	Cable 1 status
40003	Cable 1 distance or probe number
40004	Cable 2 status
40005	Cable 2 distance or probe number
40006	Cable 3 status
40007	Cable 3 distance or probe number
40008	Cable 4 status
40009	Cable 4 distance or probe number
40010	Cable 5 status
40011	Cable 5 distance or probe number
40012	Cable 6 status
40013	Cable 6 distance or probe number
40014	Cable 7 status
40015	Cable 7 distance or probe number
40016	Cable 8 status
40017	Cable 8 distance or probe number

The cable status values are:

0	Not installed
1	Off Line
2	Normal
3	Leak
4	Break
5	Short
6	Probe active
7	Probe reset
8	Drying
9	No end/Fault in 1 <sup>st</sup> 50 feet

## 4.0 Configuration Dialog

Parameters such as number of Modbus Host Address, Asynchronous Formats, and Baud Rates may be altered in the unit via Port 2 and saved in battery backed up Random Access Memory (RAM). Any terminal or PC equipped with a terminal emulator package such as HyperTerminal may be used to respond to the configuration dialog. The configuration rate is 9600 baud. The asynchronous format of the characters is 1 start, 8 data, and 1 stop bit. The configuration software handles X-ON/X-OFF flow control. Pressing the pushbutton (for more than 1 second) on the back of the unit until the Front Panel Led is extinguished will put the unit into configuration mode. At this time the message "MODBUS TO PAL-AT CONVERTER – 2003-OCT-02 REV. 1.0 CONFIGURATION MODE - PRESS ENTER OR C TO PROCEED, CONTROL R TO RESET TO UNIT DEFAULT PARAMETERS, OR ESCAPE TO RETURN TO NORMAL OPERATION" is repeatedly sent out Port 2. If the message is sent out ten times without a response, the unit will return to Normal Operation automatically. Once "ENTER" is input the configuration dialog begins. The "ESCAPE" key must be pressed to return to normal operation.

The configuration method is of the question and answer type. The description of the configurable parameter and it's current value followed by a "?" is output. If the value is only to be viewed, pressing "ENTER" will leave the value unaltered and display the next parameter or pressing "CONTROL B" will display the previous parameter. If the value is to be altered, the new value is typed, followed by "ENTER". Typing the "BACKSPACE" or "DELETE" keys can erase erroneous input.

After configuration is complete or to abort the dialog at any time, the "ESCAPE" key should be pressed. The message "RETURNING TO NORMAL OPERATION!" will be output and the unit will begin operation with the new parameters.

If "CONTROL R" rather than "ENTER" is pressed, the message "RESTORE DEFAULT CONFIGURATION (Y,N)?" is asked. If "Y" followed by "ENTER" is entered, the unit will be made to reset all its parameters to default values.

### 4.1 MODBUS/PAL-AT ADDRESS (1 TO 254)

This parameter selects the Modbus Slave Address and the PAL-AT Address to poll. The address selected must match the address entered in the PAL-AT Special Function Menu for "Set System Identification." The current default is 1.

### 4.2 HOST MODBUS RATE

This parameter is used to set the Modbus Port 1 baud rate. Values allowed are 110, 300, 600, 1200, 2400, 4800, 9600, and 19200 baud. The current default rate is 9600 baud.

### 4.3 MODBUS FORMAT 8 DATA – EVEN (0), ODD (1), NONE (2)

Modbus asynchronous format can be configured for 1 start, 8 data, even, odd, or no parity, and 1 stop bit. The current default is 2, which translates into 1 start, 8 data, no parity, and 1 stop bit.

### 4.4 PAL-AT PORT RATE

This parameter is used to set the Port 3 baud rate. Values allowed are 1200, 2400, 4800, and 9600 baud. The current default rate is 9600 baud.

### 4.5 PAL-AT POLL DELAY TIME

This parameter is used to set the pause between the requests for data from the PAL-AT unit. The

current default rate is 30 seconds.

#### 4.6 MODBUS RTS CONTROL - OFF (0), ON (1)

This option allows RTS to be set high (TX ON) during output from the Converter to the Host. Option 4.7 sets the time from RTS going high until the first character of a response is sent out Port 1. This time can be used for RS-485, 202 modem, or radio carrier stabilisation before transmission. If control is OFF, RTS is always asserted. The default option is 0 (OFF).

#### 4.7 MODBUS RTS TX DELAY T.O.

This option is only available if option 4.6 is selected ON. This timeout specifies the time to begin sending characters from Port 1 after RTS is set high. RTS is not set low (modem carrier off) until all characters are sent. Timeout values from 20 to 2000 milliseconds may be specified. The default timeout is 20 ms.

#### 5.0 Radio Frequency Information

The unit has been tested and found to comply with the limits of a Class A computing device in accordance with the specifications in part 15 of the FCC rules, which are designed to provide reasonable protection against RF interference in a commercial installation. However, there is no guarantee that interference will not occur in a particular installation. If this equipment does cause interference to radio or TV reception, the following measures may be attempted:

- Reorient the antenna of the device detecting interference.
- Relocate the device away from the PLC09 CONVERTER.
- Use different branch outlets to power the device.

The booklet "HOW TO IDENTIFY AND RESOLVE RADIO-TV INTERFERENCE PROBLEMS" prepared by the FCC may also be helpful.